

The Gnat 1: A One-Transistor CW Transceiver for HF Frequencies

by

Chris Trask / N7ZWY
Sonoran Radio Research
P.O. Box 25240
Tempe, AZ 85285-5240

Email: christrask@earthlink.net

20 February 2009
Revised 22 February 2009
Revised 25 February 2009

Introduction

Among the diverse areas of interest in amateur radio, the design, construction, and operation of transmitters, receivers, and transceivers that encompass a minimum of components has become increasingly popular amongst those in the QRP community. Lacking the more sophisticated features of commercially available rigs and kits, these simple projects offer the user an opportunity to better understand the electronics associated with radio and at the same time develop operating skills, abilities which will remain with the user and form a good basis for furthering their understanding.

Transmitters and receivers making use of a single transistor are fairly common, the transmitter being a power oscillator and the receiver being a regenerative detector. A transceiver using a single transistor is an interesting challenge from a design standpoint. A few designs exist that make use of a multiple-pole switch or relay to switch the transistor from one circuit to

another, but a switchless circuit that makes use of the key alone to switch from receive to transmit mode is not at all common.

The Gnat 1 Transceiver

A transceiver encompassing a single transistor was designed and a couple of prototypes were built for evaluation. Named herein as the "Gnat 1", the schematic and parts list appears in Fig. 1. Parts values for the resonant tank circuit (C3, C4, C7, and T1) are chosen for the frequency of operation and are listed for various HF bands in Table 1. The construction of transformers T1 and T2 will be discussed later, as will the altering of the component values for other frequencies. In this circuit, the key together with transformer T2 provides the necessary switching from transmitting to receiving mode.

Transmitter Theory

When the key is closed the circuit becomes a transmitter. The secondary side of

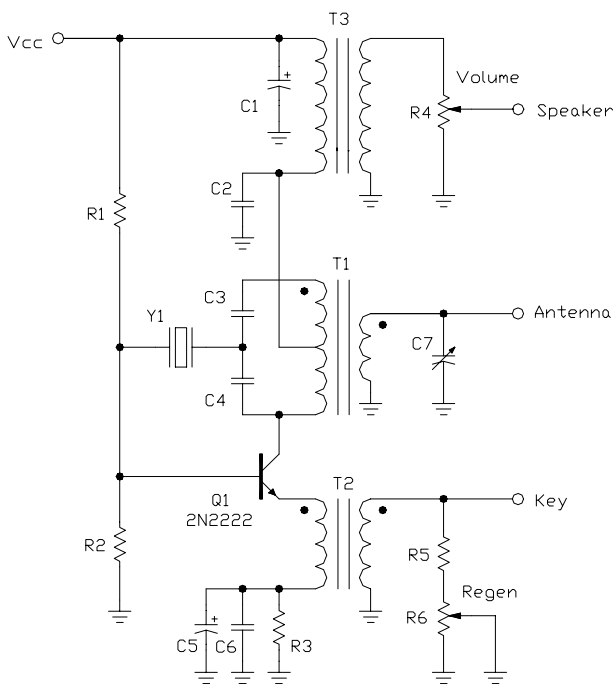

C1, C5 - 47uF 16WVDC Aluminum Electrolytic
C2, C6 - 0.1uF C7 - 25pF Variable
C3, C4 - See Table 1

Q1 - 2N2222 or 2N4401 (see text)

R1 - 33K R4 - 5K Variable
R2 - 15K R5 - TBD (short)
R3 - 33 ohms R6 - 500 ohm Variable

T1 - 2CT:1 Transformer (see text)

T2 - 1:1 Transformer (see text and Table 1)

T3 - 8 ohm to 1K audio transformer (Xicon 42TL013-RC, available from Mouser, or Radio Shack 273-1380)

Y1 - See Table 1

Figure 1 - Schematic and Parts List for the Gnat 1 Transceiver

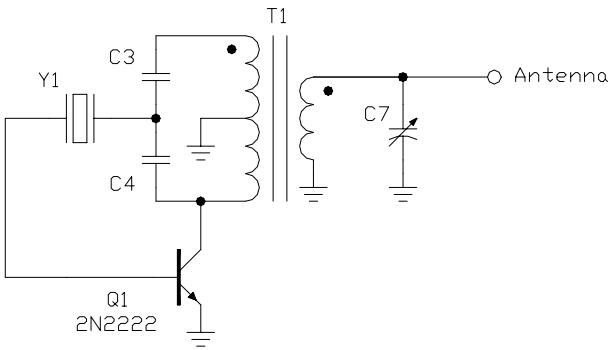

Figure 2 - Gnat Transmitter RF

transformer T2 is shorted and the emitter of the transistor is connected to ground. At the same time, capacitor C2 couples the centre tap of transformer T1 to ground and the circuit takes on the form of a simple oscillator, as shown in the functional schematic of Fig. 2. Using a centre tap on the primary side of T1 provides the needed 180° phase shift needed for the oscillator and avoids having to add a third winding. With a 2CT:1 winding ratio and a 12V supply, the oscillator can develop 0.5W peak, and with a 2CT:2 ratio it can develop 2W peak.

Receiver RF Theory

When the key is open, the circuit becomes both a regenerative detector and an audio amplifier. With regard to the RF operation of the receiver, everything is essentially the same as for the transmitter except that the transistor

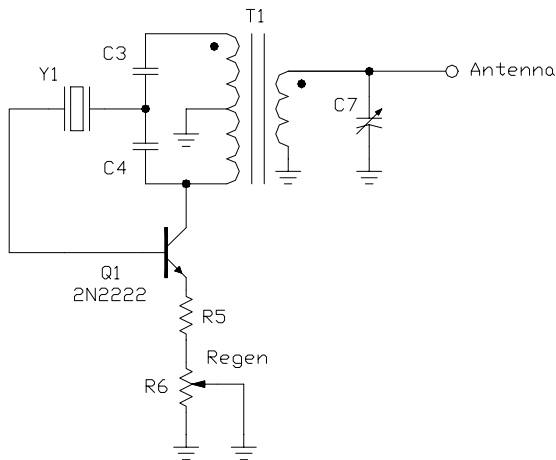

Figure 3 - Gnat Receiver RF

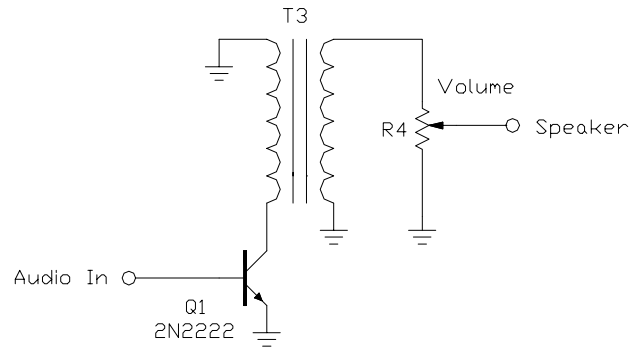

Figure 4 - Gnat Receiver Audio

emitter now sees the resistors R5 and R6, which together provide the negative feedback needed to control the onset of oscillation, all of which is shown in the functional schematic of Fig. 3. Keeping in mind that a regenerative detector is basically an oscillator that isn't, potentiometer R6 is adjusted to a point just below which the circuit oscillates. By keeping the positive feedback gain of the oscillator low by way of the ratio of C3 and C4, there is very little hysteresis in the detector, which means that if the circuit breaks into oscillation little adjustment of R6 is required to return the circuit to a regenerative detector.

Receiver Audio Theory

The regenerative detector develops an audio signal across the base-emitter junction of the transistor, and for discussion purposes we'll simply say that it appears at the base terminal. As shown in the functional schematic of Fig. 4, at audio frequencies transformer T2 does not couple to the secondary side, and the inductance of the primary is so small that it appears as a short circuit, and capacitor C5 of Fig. 1 couples the transistor emitter to ground.

At the same time, transformer T1 becomes equally transparent and capacitor C2 becomes a de-emphasis filter. The resulting audio signal appears across the primary winding of transformer T3 and is coupled to the secondary side to volume control R4 and then to



Figure 5 - Gnat 1/40 Prototype

the speaker, which would most suitably be a high impedance earplug.

Prototype Construction

A couple of prototypes were constructed and tested, the cleaner of which is shown in Fig. 5. Constructed on a commercial perf board with plated-through holes spaced 0.1" apart, the circuit takes up about two square inches. Re-

generation control R6 is at the lower end of the photo and volume control R4 is at the top.

For the 40m band, capacitors C3 and C4 are 120pF and 82pF, respectively. Table 1 lists values of these components for other bands. For additional operating bands, the values for C3 and C4 can be simply scaled by way of the ratio of the desired operating frequency, as can be the number of turns used on transformer T1, or a different core can be used.

For the 40m band, transformer T1 is constructed with 15 turns of #30 trifilar wire on a Micrometals T37-6 toroid core, and Table 1 lists the number of turns required for other bands. A photograph of T1 as built for the 80m band is shown in Fig. 7. After winding the required number of turns on the toroid core, both ends of one strand of the trifilar bundle are separated to the left for the secondary winding. An opposite pair of ends of the remaining two strands are twisted together to form the centre tap, and the remaining two leads are separated out to form the primary end terminals. The wires are then tinned prior to installation.

T2 is a simple 1:1 transformer made with 4 turns of #30 bifilar wire wound on a Fair-Rite 2843002402 binocular core, and is illustrated in Fig. 7. These turns should be wound fairly tightly and the leads should be kept short as

Frequency	3.5MHz	7.0MHz	10.0MHz
C3	270pF	120pF	82pF
C4	180pF	82pF	56pF
T1	20 turns #30 trifilar wire on T37-6 core	15 turns #30 trifilar wire on T37-6 core	12 turns #30 trifilar wire on T37-6 core
Y1	3.598MHz	7.030MHz	10.130MHz

Table 1 - Values for Frequency-Dependent Components



Figure 6 - T1 Construction Details
(80m version shown)

excessive stray inductance will cause a shift in frequency between the receive and transmit modes.

Transformer T3 is connected with the 8-ohm side used as the primary (left) and the 1K side used as the secondary (right) so as to provide additional voltage gain as well as reduce the DC resistance in the path between the supply voltage and the collector of Q1.

Regardless of the style of construction, some adjustment may be required as the tank circuit should resonate fairly close to the crystal frequency so as to operate properly. This adjustment is easily accomplished by first setting the trimmer capacitor C7 to its mid-range position and shorting the leads of the crystal. Connect a load to the antenna terminal and apply the supply voltage. Using a frequency counter or a scope measure the frequency of the circuit while in the transmit mode (key

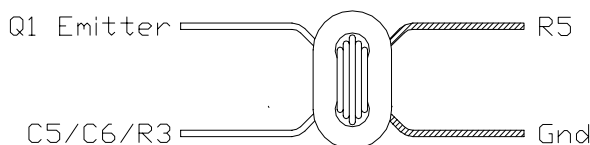

Figure 7 - T2 Construction Details

closed). If the frequency cannot be adjusted to the crystal frequency by way of trimmer capacitor C7, add or subtract a turn at a time from transformer T1 (coarse adjustment) or adjust the values of capacitors C3 and C4 (fine adjustment). If the frequency is slightly high, it may be even more convenient to simply add a small fixed capacitor across C7. This may take some degree of effort and patience but is necessary due to all sorts of variables, especially if a different sort of transistor is used for Q1.

Printed Circuit Board

The small number of components used in the Gnat makes construction on a small piece of perf board fairly easy, but for those who have a need for a more formal and robust method of construction, a printed circuit board (PCB) layout is provided in Fig. 8, and the parts placement is shown in a larger form in Fig. 9.

The potentiometers used for R4 and R6 in the PCB layout are CTS series 201, which are inexpensive, very rugged, and are available from Digi-Key. The variable capacitor C7 is a Sprague series GAE, and similar parts are made by Johnson and Erie. These are also very rugged and can be found from distributors such as Surplus Sales of Nebraska and Dan's Small Parts. Most builders will undoubtedly prefer to use panel-mounted variable components, which will require the addition of wires between

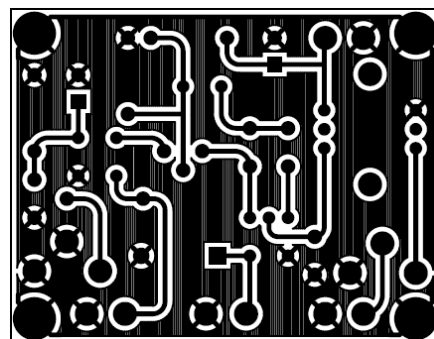

Figure 8 - Gnat PCB (full size, solder side copper)

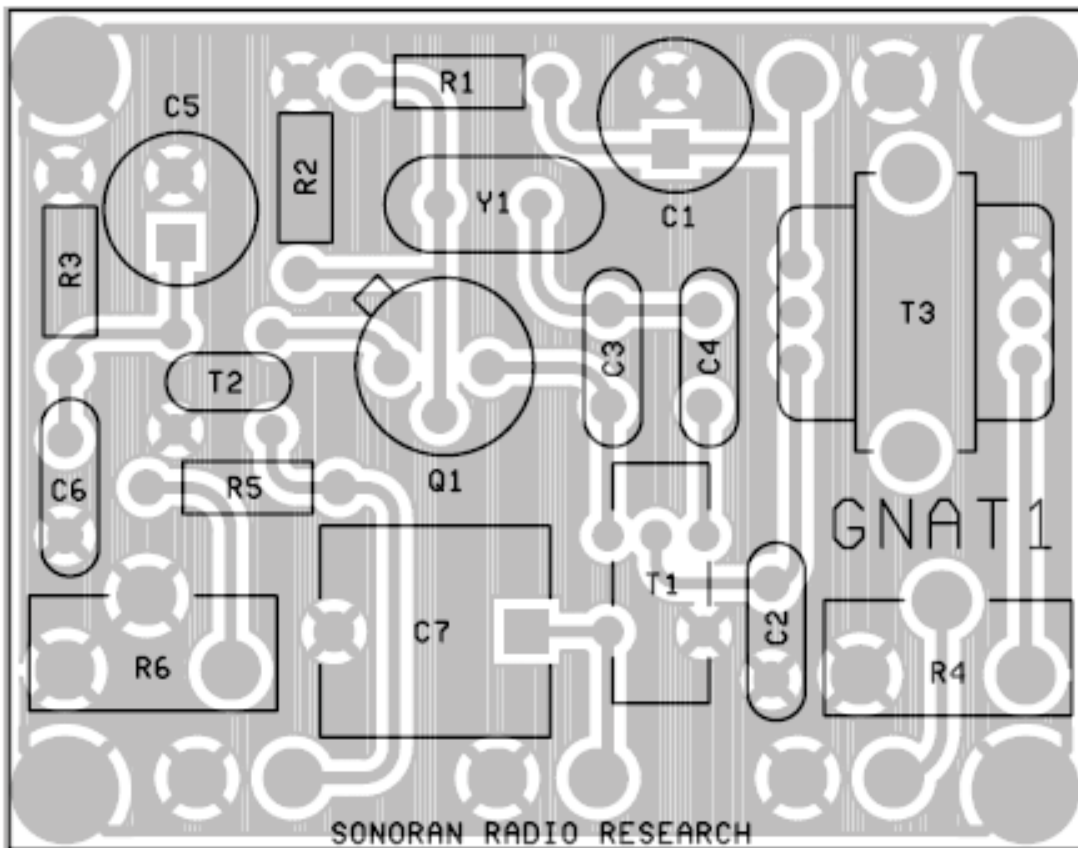

Figure 9 - Gnat PCB Parts Placement

the PCB and the control variables.

The pads for transistor Q1 are for the TO-5/TO-39 package so that devices such as the 2N3866 may be used. These pads will also accommodate smaller packages such as the TO-18 and TO-92.

The pads for transformer T3 are for the Xicon 42TL series of ultraminiature audio transformer that appears in the parts list of Fig. 1, which are available from Mouser. These PCB mounted transformers have a very small footprint and are ideally suited for applications such as this.

The space provided for transformer T1 is intended to accommodate toroid cores up to 1/2" diameter, which will be required for those wishing to increase the power level up to 2W or for lower frequencies that will require more than the

20 turns that the T37 size core can accommodate.

Pads for attaching power leads are provided in the upper right-hand corner, and pads for the key, antenna, and speaker are arranged from left to right in that order along the bottom edge together with accompanying ground pads.

Synopsis

Designing the Gnat 1 transceiver continues to be a fun project, and refinements continue as time allows. Simple multi-function circuits such as this are very often compromises in performance, and the builder should anticipate that some degree of variation will occur as building practices and components (especially transistors) will cause variations in performance. Despite this, having a one-transistor transceiver that does not incorporate a multi-pole switch or relay is quite a lot of fun.